

TYPE D HYDRO-LOCK SLEEVE

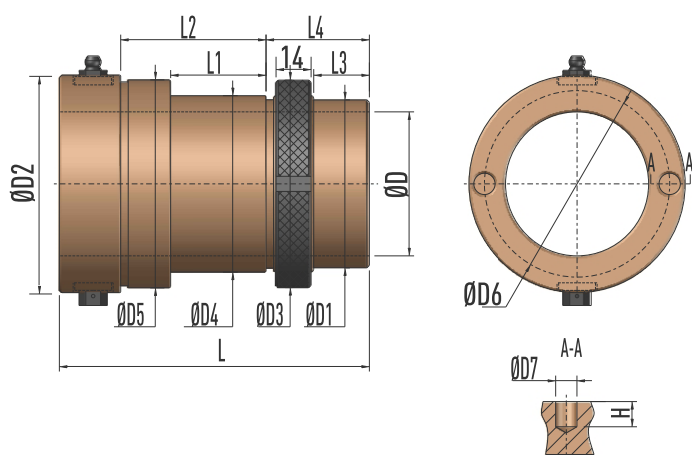
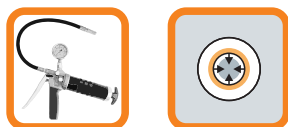

Product Description

Type D hydro-lock sleeve is for assembly of support bearings for machines with bearings at both ends of the spindle.

Max. Speed: 9000 rpm, Operation Pressure: 40-45MPa.

Highlight Features

1. Pressurized with grease pump for easy and quick assembly;
2. Compact in size along the radial direction, structurally stable;
3. The built-in lock nuts enable an easy and accurate tool adjustment and promote operation safety.

Product Specifications

SKU	Product	D	D1	D2	D3	D4	D5	D6	D7	L	L1	L2	L3	L4	H
G011 70006	D 2-1/4"/2.756" x 4-7/8" 2-1/4"	66.68	86.36	82.55	2.756"	82.55	74	8.5	4-7/8"	38.1	58.05	22.23	41.28	10	
G011 70007	D 3"/3.544" x 5-5/8"	3"	85.73	111	111	3.544"	-	-	-	5-5/8"	50.8	-	25.25	47.55	-
G011 70008	D 3-15/16"/6" x 2-1/2" 3-15/16"	-	189.4	189.4	6"	-	-	-	2.5"	3.5	-	-	34.6	-	

Please note that except for the dimensions marked in imperial, all the other dimensions in the above table are in metric (mm).